

Varimixer

AR100

STRONG AND EFFECTIVE The powerful motors have the capacity to handle large quantities of heavy ingredients.

VARIABLE SPEED CONTROL The speed is variably controlled by a very rugged system of belts, rather than gears. This solution means that the mixer does not contain oil, thus avoiding the risk of oil spilling into the bowl.

DIGITAL TIMER operation time can be controlled or monitored via a digital timer. The machine stops at 00:00

MULTIPLE CAPACITIES IN ONE MACHINE

Bowls and tools are available for production of both 100, 60 and 40 liter.

PLASTIC OR STAINLESS STEEL SAFETY GUARD

The AR series comes with a CE-approved safety guard made of plastic to prevent flour dust and stains. It's filling chute can be used during operation. It is also available with a removable plastic guard, or a fixed or removable stainless steel guard.

AUTOMATIC FIXATION The bowl is wheeled into place between the two bowl arms. Using the handle – or automatically by pressing a button – the bowl is raised, centered and locked in place in a single movement.

EASY BOWL HANDLING Choose between bowl truck for transport or an electric bowl lift, which handles transport to and from the machine and all bowl lifts. This also ensures good ergonomics during filling and emptying. Choose between several models.

WHITE OR STAINLESS STEEL An easy-to-clean design. The AR series is powder coated as standard and can be upgraded to a completely stainless steel frame.



VARIMIXER AR100 OPTIONS – MODELS



White, powder coated



Stainless steel



Marine version, stainless steel

OPTIONS – CONTROL PANEL



VL-1L – Manual speed regulation and automatic bowl lowering



VL-1S – Automatic speed regulation and automatic bowl lowering

OPTIONS – SAFETY GUARDS



Fixed safety guard in plastic.
CE-certified



Removable safety guard in
plastic. CE-certified



Fixed safety guard in stainless
steel. Not CE-certified

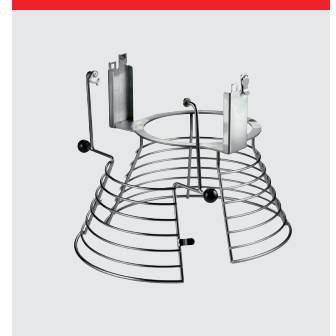

Removable safety guard in
stainless steel. Not CE-certified

VARIMIXER AR100 STANDARD TOOLS – A-EQUIPMENT 100L



Whip, hook, beater and bowl 100 liter in stainless steel.

VARIMIXER AR100 STANDARD TOOLS – B-EQUIPMENT 100/60L AND C-EQUIPMENT 100/40L



Whip, hook, beater and bowl 100/60 liter in stainless steel and Whip, hook, beater and bowl 100/40 liter in stainless steel.

OPTION – TOOLS



Wing whip, stainless steel



Whip with 1 mm thicker wires, stainless steel



Whip with thinner wires, stainless steel



Whip with reinforcement



Beater, stainless steel



Automatic scraper, stainless steel. Nylon or teflon blade. 100L, 100/60L, and 100/40L.



Powder mixer, stainless steel



Tool rack, 127 cm

EQUIPMENT



Bowl truck



Easylift 80-140



Maxilift Inox

VARIMIXER AR100 STANDARD

White powder coated
1 bowl 100 liter in stainless steel
1 beater in aluminium (food grade)
1 hook in stainless steel
1 whip with stainless steel wires
Fixed safety guard in plastic – CE-certified
Digital timer and emergency stop
Voltage: 3 ph, 400V, 50 Hz with 0 and ground. 2.900 W

VARIMIXER AR100 STANDARD TECHNICAL DATA

Volume	100 l
Effect	2.900 W
Standard voltage*	400 V
Residual current devices (RCD):	
Industrial environment	PFI type A
Light industry/domestic	HPFI type A
Net weight	395 kg
H x W x L	1593 x 691 x 1171 mm
Variable speed	47 – 257 RPM
Phases	3 ph
IP code	IP32

*Other voltage power supply are available upon request in the range of 100 to 480 V.
All standard and marine mixers are available in 50 and 60 Hz.

CAPACITIES

Egg Whites	15 l
Whipped cream	45 l
Mayonnaise	80 l
Herb butter	75 kg
Mashed potatoes	65 kg
Bread dough (50% AR)	58 kg
Bread dough (60% AR)	70 kg
Ciabatta dough (70% AR)	75 kg
Muffins	60 kg
Layer cake base	25 kg
Meatball mix	75 kg
Icing	70 kg
Doughnut (50% AR)	60 kg

VARIMIXER AR100 MARINE VERSION

Stainless steel execution, water cover at air ventilation, slotted free screws, full welded stainless steel knees, gasket at the rear plate, gasket at front panel and top cover. Complies with USPHS.

Voltage: 3 ph, 440V, 50-60 Hz with 0 and ground. 2.900 W
3 ph, 480V, 50-60 Hz with 0 and ground. 2.900 W

DIMENSIONS

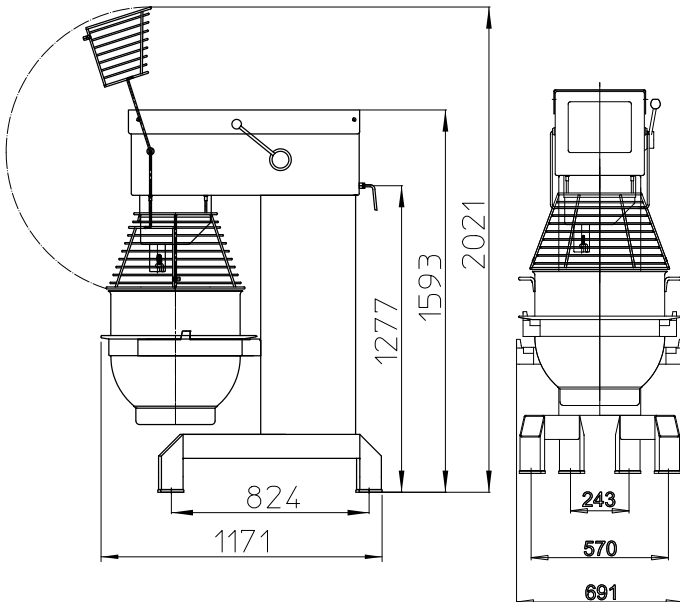

CERTIFICATIONS



Varimixer

Varimixer A/S
Kirkebjerg Søpark 6
DK-2605 Brøndby
P: +45 4344 2288
E: info@varimixer.com
www.varimixer.com