

Varimixer

AR30

MULTIPLE CAPACITIES IN ONE MACHINE Bowls and tools for production at half volume are available for AR30

DIGITAL TIMER operation time can be controlled or monitored via a digital timer. The machine stops at 00:00

MEAT MINCER AND VEGETABLE CUTTER Models from AR30 to AR80 can be ordered with an attachment drive, to expand the mixer's potential applications.

PLASTIC OR STAINLESS STEEL SAFETY GUARD The AR series comes with a CE-approved safety guard made of plastic to prevent flour dust and stains. It's filling chute can be used during operation. It is also available with a removable plastic guard, or a fixed or removable stainless steel guard.

AUTOMATIC FIXATION The bowl is wheeled into place between the two bowl arms. Using the handle - or automatically by pressing a button - the bowl is raised, centered and locked in place in a single movement.

EASY BOWL HANDLING Choose between bowl truck for transport or an electric bowl lift, which handles transport to and from the machine. This also ensures good ergonomics during filling and emptying. Choose between several models.

STRONG AND EFFECTIVE The powerful motors have the capacity to handle large quantities of heavy ingredients.

VARIABLE SPEED CONTROL The speed is variably controlled by a very rugged system of belts, rather than gears. This solution means that the mixer does not contain oil, thus avoiding the risk of oil spilling into the bowl.



WHITE OR STAINLESS STEEL An easy-to-clean design. The AR series is powder coated as standard and can be upgraded to a completely stainless steel frame.

VARIMIXER AR30 OPTIONS – MODELS



White, powder coated



Stainless steel



Marine version, stainless steel

OPTIONS – CONTROL PANEL



VL-1 – Manual speed regulation and manual bowl lowering



VL-1S – Automatic speed regulation and automatic bowl lowering

OPTIONS – SAFETY GUARDS



Fixed safety guard in plastic. CE-certified



Removable safety guard in plastic. CE-certified



Fixed safety guard in stainless steel. Not CE-certified



Removable safety guard in stainless steel. Not CE-certified

OPTIONS – ATTACHMENT DRIVE



Attachment drive for meat mincer and vegetable cutter



Meat mincer, 70 mm



Meat mincer, 82 mm



Vegetable cutter GR20

VARIMIXER AR30 STANDARD TOOLS – A-EQUIPMENT 30L

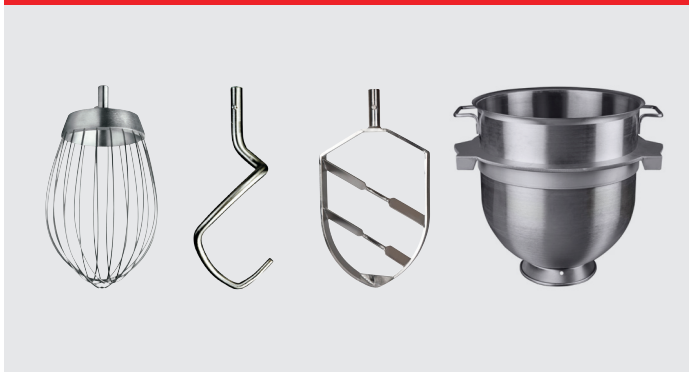

Whip, hook, beater and bowl 30 liter in stainless steel.

VARIMIXER AR30 STANDARD TOOLS – B-EQUIPMENT 30/15L



Whip, hook, beater and bowl 30/15 liter in stainless steel.

OPTION – TOOLS



Wing whip, stainless steel



Whip with 1 mm thicker wires, stainless steel



Whip with thinner wires, stainless steel



Automatic scraper, stainless steel. Nylon or teflon blade. 30L and 30/15L.



Powder mixer, stainless steel



Tool rack

EQUIPMENT



Bowl truck



Easylift 30-60



Multilift 30-60



Flexlift Inox

VARIMIXER AR30 STANDARD

White powder coated
1 bowl 30 liter in stainless steel
1 beater in stainless steel
1 hook in stainless steel
1 whip with stainless steel wires
Fixed safety guard in plastic – CE-certified
Digital timer and emergency stop
Voltage: 3 ph, 400V, 50 Hz with 0 and ground. 1.000 W

VARIMIXER AR30 STANDARD TECHNICAL DATA

Volume	30 l
Effect	1.000 W
Standard voltage*	400 V
Residual current devices (RCD): Industrial environment	PFI type A
Light industry/domestic	HPFI type A
Net weight	170 kg
H x W x L	1210 x 520 x 910 mm
Variable speed	57 – 311 RPM
Phases	3 ph
IP code	IP32

*Other voltage power supply are available upon request in the range of 100 to 480 V.
All standard and marine mixers are available in 50 and 60 Hz.

VARIMIXER AR30 MARINE VERSION

Stainless steel execution, water cover at air ventilation, slottet free screws, full welded stainless steel knees, gasket at the rear plate, gasket at front panel and top cover. Complies to USPHS.

Voltage: 3 ph, 440V, 50-60 Hz with 0 and ground. 1.000 W
3 ph, 480V, 50-60 Hz with 0 and ground. 1.000 W

DIMENSIONS

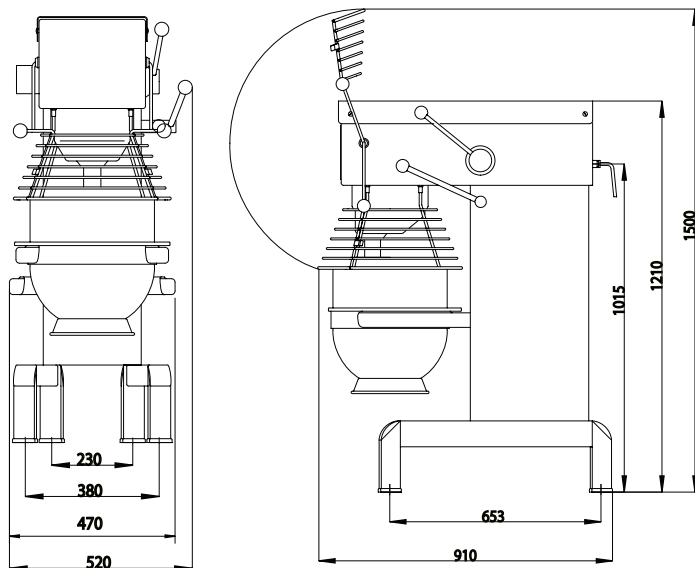

CERTIFICATIONS



Varimixer

Varimixer A/S
Kirkebjerg Søpark 6
DK-2605 Brøndby
P: +45 4344 2288
E: info@varimixer.com
www.varimixer.com